

- NOTES:**
1. CONTRACTOR TO GROUT FLOOR OF WET WELL AT 1% SLOPE TO FLOOR DRAIN. MIN 1" THICK GROUT AROUND DRAINS.
 2. FACTORY COATED DUCTILE IRON PIPE IN WET WELL.
 3. OVER EXCAVATE 2'-0" MIN FILL WITH QUARRY SPALLS WSDOT 9-13.06 OR SHOULDER BALLAST 9-03.9.
 4. WOVEN GEOTEXTILE FOR SOIL STABILIZED PER WSDOT 9-33 TABLE 3.

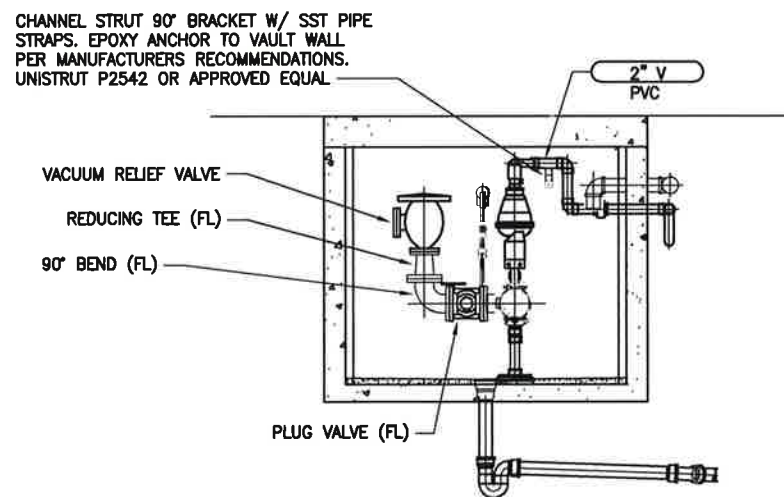

WET WELL SECTION
NOT TO SCALE

METER VAULT SECTION
NOT TO SCALE

Approved: *[Signature]* March 16, 2018
 City Engineer Date
SANITARY SEWER STANDARD DETAIL



Dwg No: **SS21**
Sanitary Sewer Lift Station
Profile View